

RECOMMENDATIONS

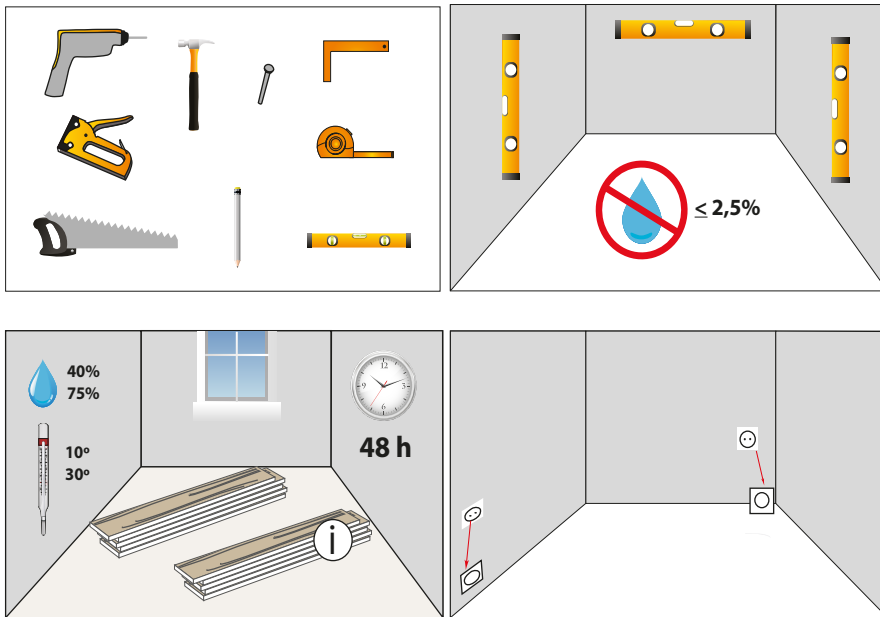

1. Always install in interiors.
2. Do not expose the product to damp areas or too close to heat sources, such as open fires, halogens...
3. Leave the boxes open for at least 24 hours in the room where they are going to be installed so that they can become acclimatised to the room temperature and humidity.
4. Do not install on newly-painted walls.
5. Install on completely flat surfaces.
6. The panels may be installed horizontally or vertically.
7. Clean with a damp cloth. Do not use abrasive products.
8. Join the panels with the sleepers by means of thin nails or staples.

* Do not use any kind of silicones for installation of the product. We recommend to use "assembly adhesives" of polyurethane, without organic solvents.

WALL INSTALLATION

Place the battens discontinuously along the wall to allow ventilation, leaving a transverse gap of 40cm and a longitudinal gap of 1cm between each batten. (Image 1).

Place the first board, always starting in the corner and keeping the minimum distances from the floor, sides, and ceiling. Ensuring squareness on this first board is very important. The groove should always go to the side where the rest of boards will be placed. Fasten the first board to the sleeper by using nails or staples, both on the left side of the piece and on the right side in the groove. It is recommended to remove the tongue to facilitate the installation of the complements (images 2-3).

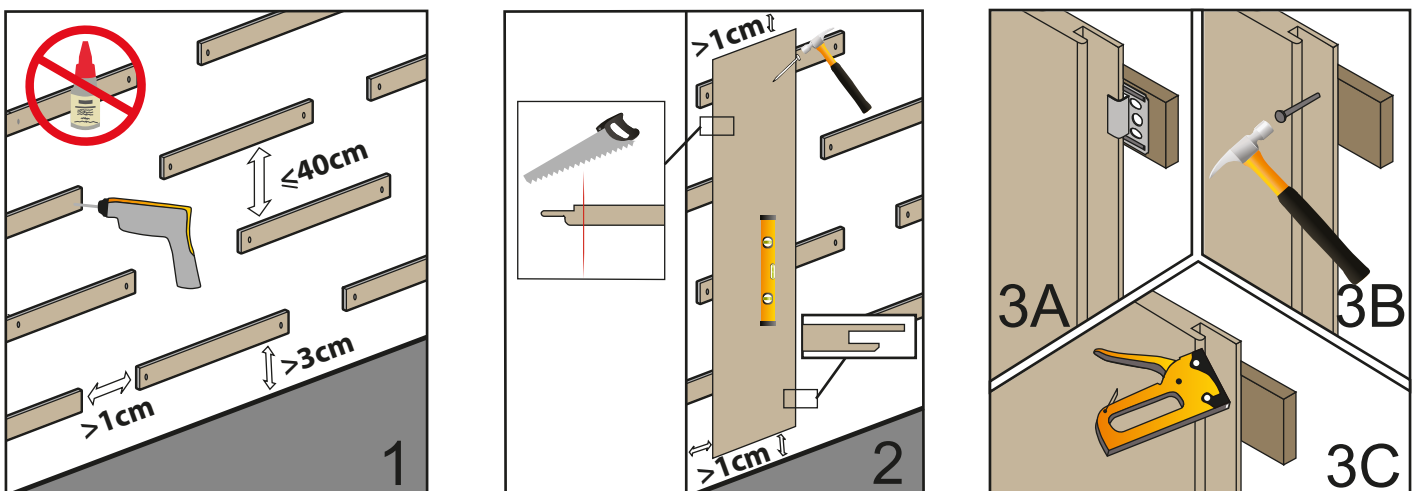

Continue by joining the rest of boards (tongue and groove) and nailing or clipping the groove of each board (images 3-4).

If the wall exceeds 10m length, use an expansion moulding (image 5).

At last, place the different accessories: skirting, corner profile, cornice, etc...

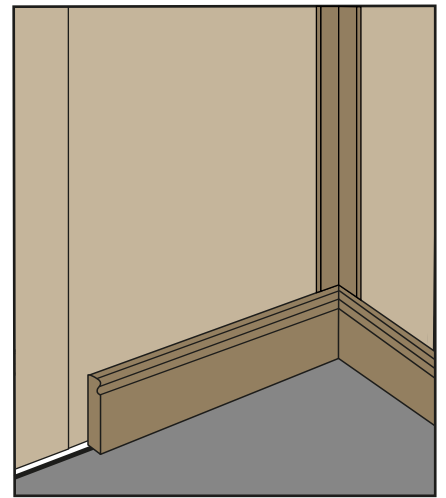
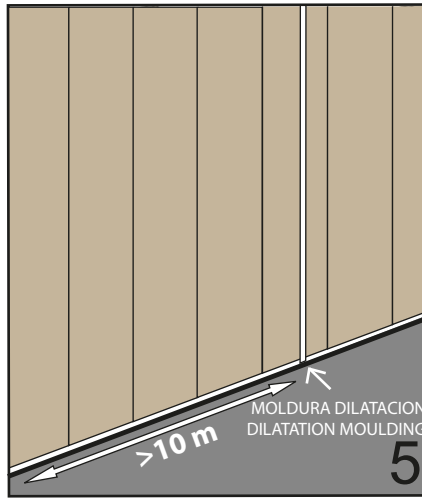
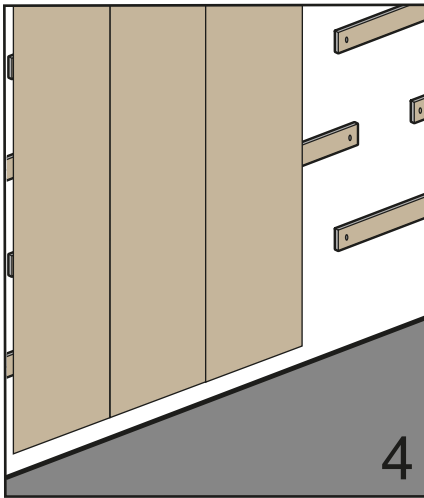

Zenku decorative panels can be placed at half height.

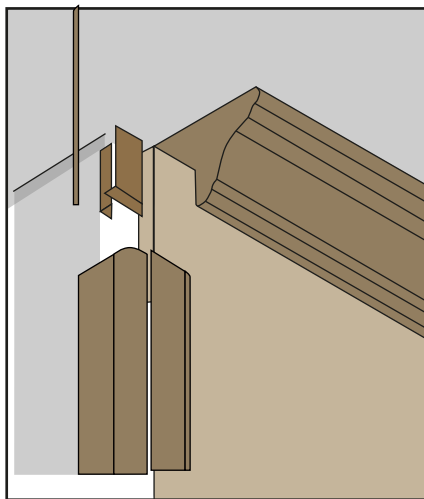

1/2 ALTURA / HEIGHT

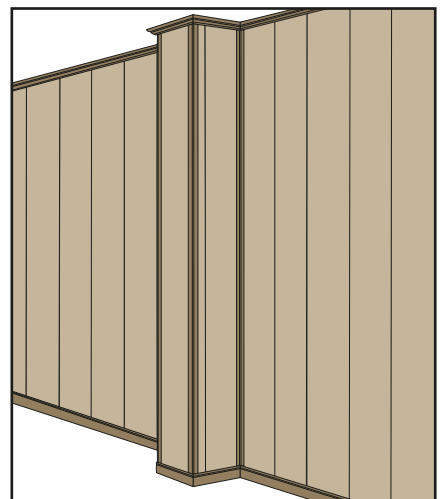
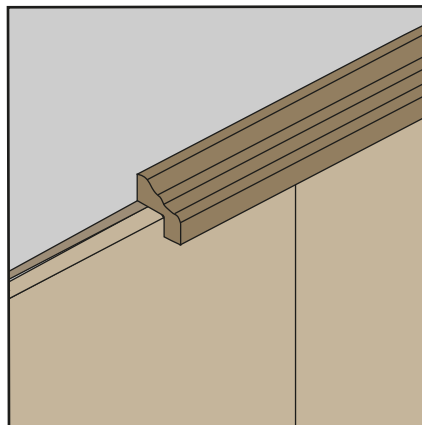

CEILING INSTALLATION

Follow the previous steps as for wall installation but, in this case, the transverse distance between sleepers must be 30cm. instead of 40cm.

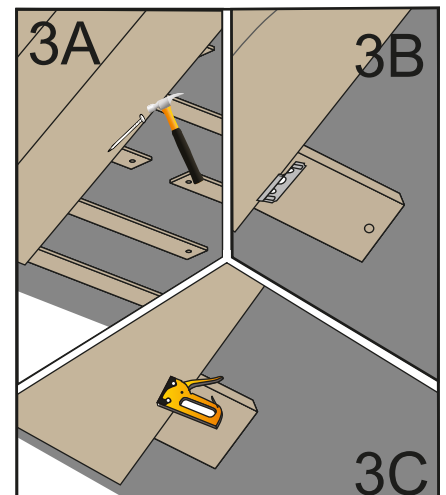
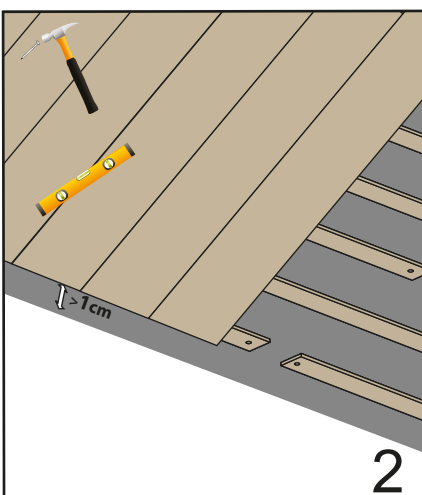
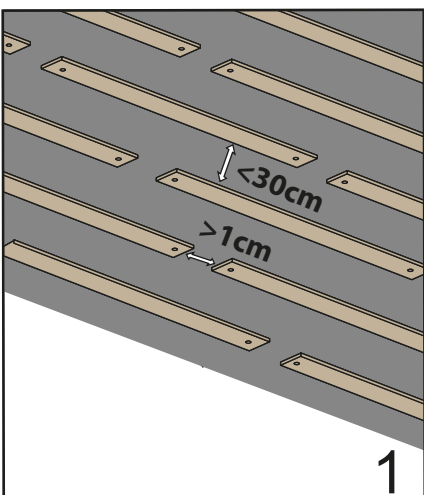

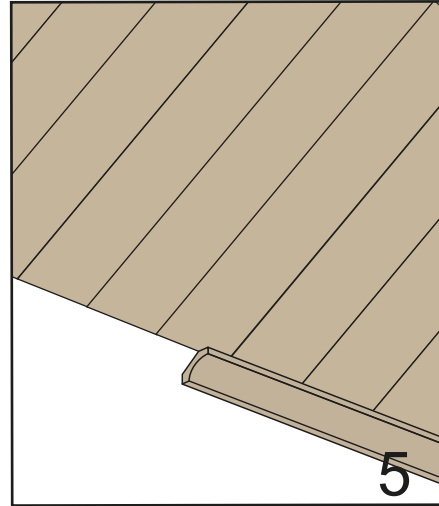
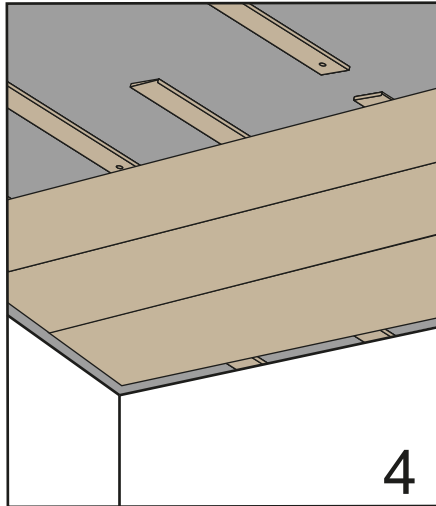

MAINTENANCE AND CLEANING

